

# TECHNOLOGY MEETS QUALITY

Takeuchi proactively responds to our customers needs through world class product design, research and development, manufacturing and after the sale product support. Welcome to the next generation of Takeuchi Excavators.

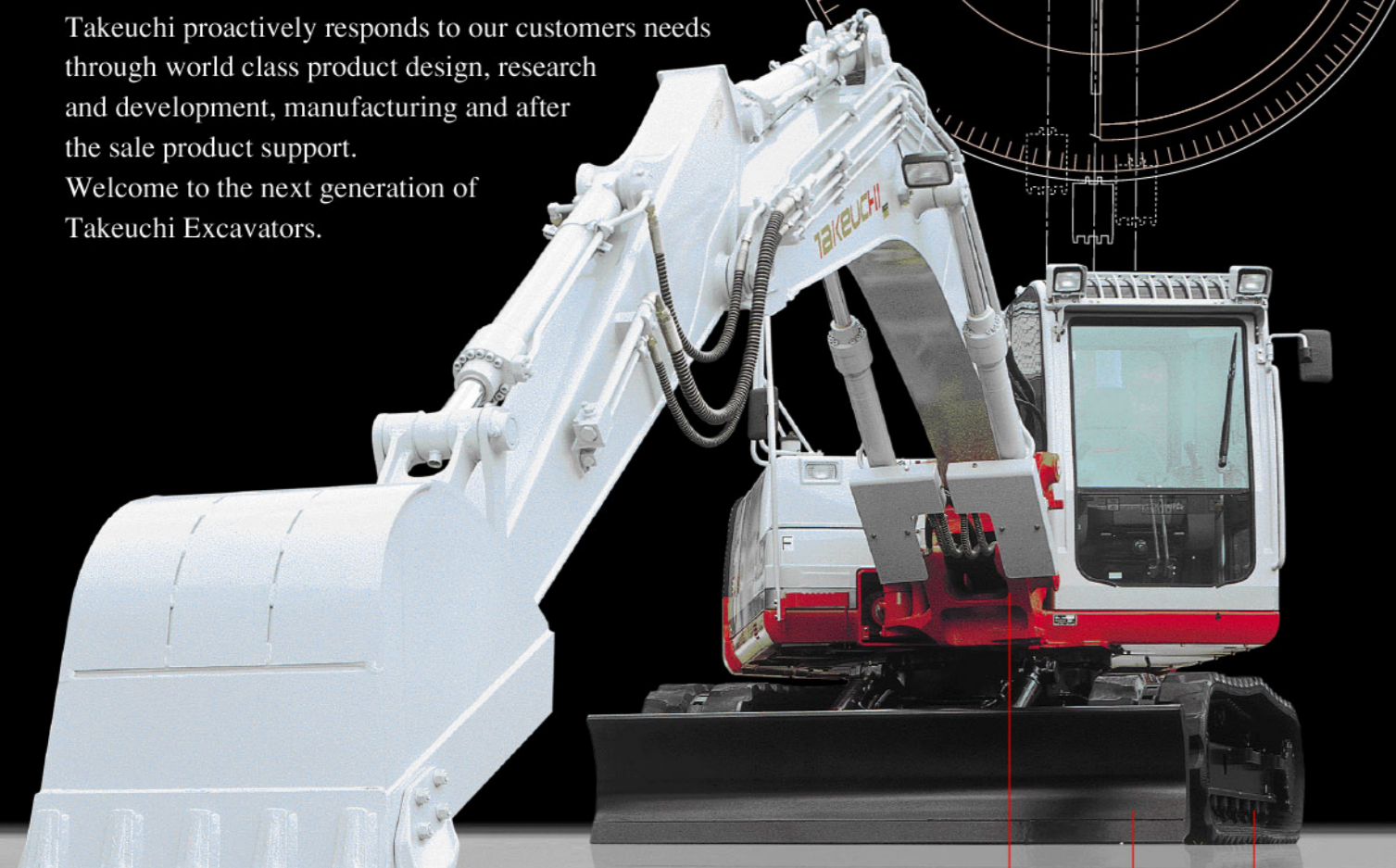

## PRINCIPLE FEATURES of the TB1140

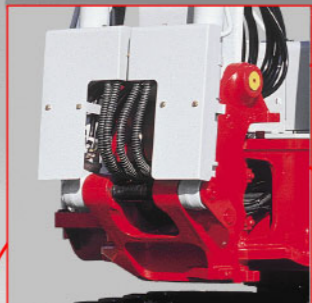

**Boom Swing**  
for digging side ditches



**Dozer Blade**  
for ground leveling

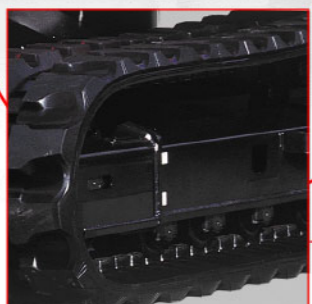

**Rubber Tracks**  
for comfortable operating

# TAKEUCHI

### OPERATING RANGE : mm

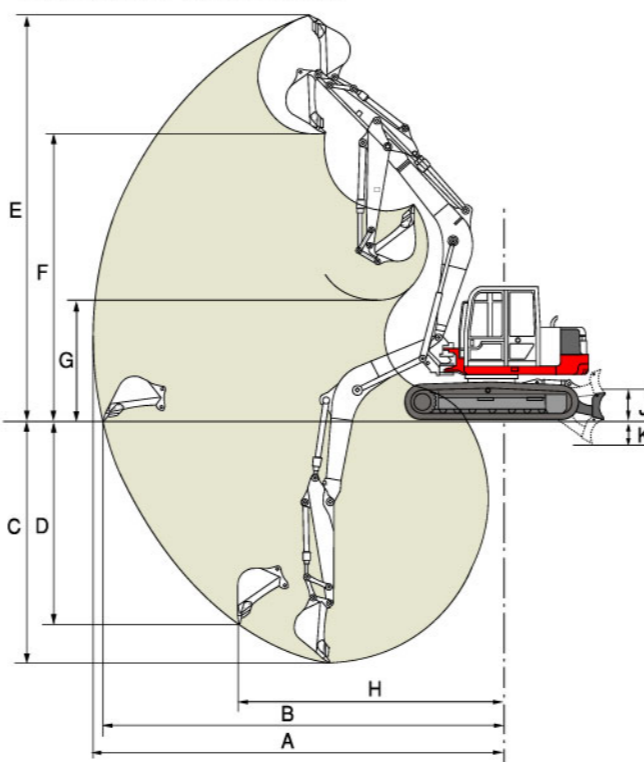

### DIMENSION : mm

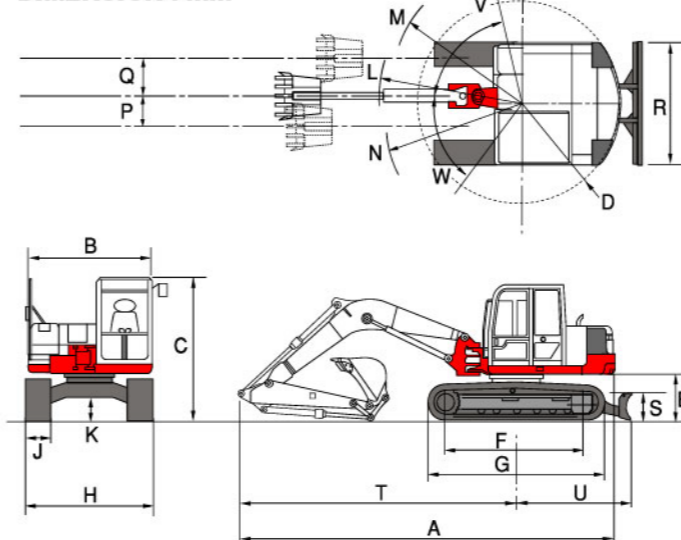

Item	Standard Arm		Long arm	
	Rubber Crawlers	Steel Crawlers	Rubber Crawlers	Steel Crawlers
A Max. Digging Radius	8280	←	8755	←
B Max. Floor Digging Radius	8080	←	8570	←
C Max. Digging Depth	4990	5000	5490	5500
D Max. Vertical Digging Depth	4145	4150	4630	4635
E Max. Digging Height	8305	8300	8665	8660
F Max. Dumping Height	5855	5850	6215	6210
G Min. Dumping Height	2335	2330	1850	1845
H Max. Vertical Digging Radius	5240	←	5355	←
J Max. Raising Height	510	500	510	500
K Max. Lowering Depth	490	500	490	500

Units:mm

A	7725	M	2255
B	2460	N	2665
C	2785	P	625
D	2000	Q	760
E	920	R	2490
F	2880	S	550
G	3590	T	5725
H	2490	U	2340
J	500	V	77
K	450	W	53
L	2855		

### SPECIFICATIONS TB1140 ( Cab, Rubber Tracked, Standard Arm, Breaker Piping Standard, Fops Cabin) (Steel Tracked: Option)

<b>WEIGHT</b>	Machine Weight	kg	14230	Rear Slew Radius	2000	<b>OPERATING RANGE : mm</b>	Max. Dig Depth	4990
<b>BUCKET</b>	Bucket Capa	m <sup>3</sup>	0.34(Struck)/ 0.45 (Heaped)	Min. Ground Clearance	450		Max. Vertical Dig Depth	4145
	Bucket Width	mm	970	<b>PERFORMANCE</b>			Max. Dump Height	5855
<b>DIESEL ENGINE (Water-Cooled)</b>	Model	ISUZU BB-4BG1TRE		Traction Speed	km/h	3.0/5.3	Max. Dig Height	8305
	Type	4CYL 4CYCL		Upper Slew Speed	rpm	13.8	Max. Dig Radius	8280
	Rated Output	kW	62.2/2050rpm	Gradeability	deg	35	Max. Floor Dig Radius	8080
	Max. Torque	Nm	304	Max Dig Power Bucket	kN	98.7	Min. Slew Radius	2255
	Displacement	cc	4329	Max Dig Power Arm	kN	64.9	Max. Bucket Offset RHLH	760/625
	Cool Water Capa.	lit	21	Ground Press	kPa	41.7	<b>HYDRAULIC SYSTEM</b>	
	Lub. Oil Capa	lit	15.8(MAX)	<b>DOZER BLADE : mm</b>			Pump type	Variable (P1+P2) +Gear (P3+P4)
	Fuel Tank Capa	lit	233	Width x Height	550X2490		Set Press	34.3x2+23.6+3.9
<b>OVERALL DIMENSION:mm</b>	Length (in transport)	7725		Operating Range up/down	510 / 490		Discharge	106.6x2+51.9+20.5
	Width	2490		<b>OFF-SET DIG FUNCTION</b>			Breaker & Service Port	l/min
	Height	2785		Type	Boom Swing		Slew Motor	Axial Piston
				Swing Angle RHLH	53°/77°		Traction Motor	Axial Piston
				<b>TRACTION SYSTEM : mm</b>			Hydraulic Tank Capa	lit
				Crawler (Track)	Rubber / Steel			95
				Track Width RT (ST)	500(500)			

WORLD CREATOR OF COMPACT EXCAVATOR  
**TAKEUCHI MFG.CO.,LTD.**

205-3,Uwadaira,Sakaki-machi, Hanisina-gun.  
Nagano 389-0605,Japan  
Phone (81)268-81-1112  
Telefax (81)268-81-1121  
URL <http://www.takeuchi-mfg.co.jp>  
E-mail:marketing@takeuchi-mfg.co.jp



In accordance with our established policy of constant improvement, we reserve the right to amend this specification at any time without notice. Printed in Japan. TK 040250

# FULL HYDRAULIC EXCAVATOR TB1140

Machine Weight : 14230 kg



# TAKEUCHI

# TAKEUCHI

## Operator Comfort



**ISOLATION MOUNTED CAB**  
minimizes noise levels and vibration within the operators station for added operator comfort and awareness of the excavators operating and worksite condition.



**MULTI - ADJUSTABLE SUSPENSION SEAT**  
provides for long days of productive operation with minimal operator fatigue.

**SHORT PITCH RUBBER TRACKS**  
provide vibration free travel even on the roughest ground condition.

**HEAT/AIR CONDITIONER**  
provides a comfortable operating environment in all climates.



## Safety

**EMERGENCY ENGINE SHUT DOWN/RETURN TO IDLE SYSTEM**  
helps protect the engine from problems due to low oil pressure or high coolant temperature.

**REAR MOUNTED WORK LIGHTS**  
improve job site safety by visually alerting anyone entering the excavators swing area.

**CAST IRON, WRAP AROUND PROTECTIVE COUNTERWEIGHT**  
protects the engine compartment from accidental damage when working in confined areas.

**SPRING - APPLIED, HYDRAULICALLY RELEASED**  
disk type parking brakes are installed on travel and slew motors for safe and reliable braking performance.



**PROTECTIVE ROUTING OF BUCKET AND ARM CYLINDER HOSES**

through the boom bracket virtually eliminates hose abrasion from narrow trench walls and excavation debris. In addition, the hose routing provides an unobstructed view to the work area.

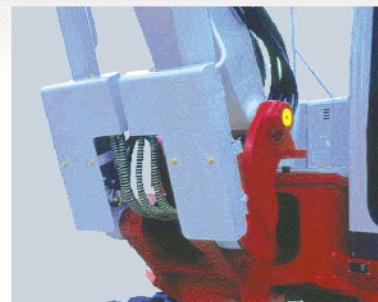

**CONSOLE SAFETY LOCKOUT LEVERS**  
disable travel and operating controls for safe entry and exit from the excavator.



**RETRACTABLE SEAT BELT**  
is designed for comfort, convenience and encouragement for operator use of this important safety feature.

**SIDE LIGHT**  
helps illuminate dark work areas.

## Ease of Operation



**HYDRAULIC ATTACHMENTS**  
are operated by momentary push button or proportionally controlled by the slider switch on the joystick.



**ONE TOUCH ENGINE DECELERATOR**  
installed on the right hand joystick reduces fuel consumption when the excavator is temporary idled.



**ENGINE SPEED**  
is easily set by feather touch button.

**TWO-SPEED TRAVEL SHIFT-DOWN SYSTEM**  
automatically shifts travel speed from high to low speed when ground conditions call for additional traction power, ease of operation.

**BOOM SWING** is operated by pedal.

**TRAVEL MOTORS**  
are equipped with shock less valves for smooth starts and stops.

## Serviceability

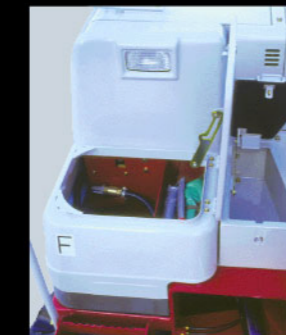

**THE FUEL SYSTEM AUTOMATICALLY BLEEDS AIR**  
from fuel lines on a fuel-depleted machine saving on time, tools and unnecessary service calls.

**HYDRAULIC TEST PORTS**  
are conveniently located for ease of hydraulic system diagnostic testing.

**GREASE GUN STORAGE**  
helps ensure that proper daily maintenance is performed.

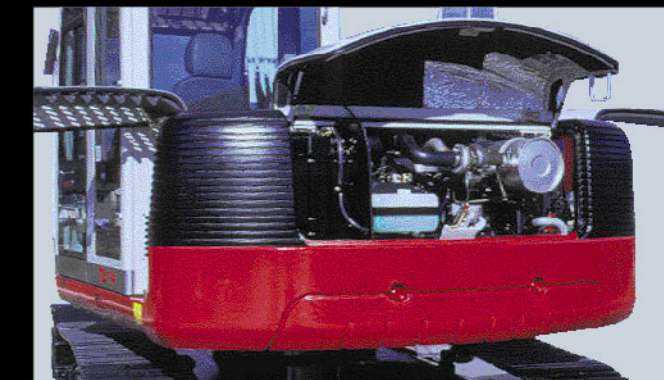

**NEW SERIES ENGINE**  
is designed to meet the most stringent worldwide exhaust emission standards and also provides significantly reduced noise levels for minimal disturbance in urban areas.



**FULL OPENING REAR ENGINE COMPARTMENT**  
allows daily machine servicing to be conveniently accomplished from ground level.

## Options

**TKB801 HYDRAULIC BREAKER**  
is matched to the excavators hydraulic flow, pressure and operating capacity, enabling the excavator to efficiently perform concrete breaking and demolition work.

**2nd AND 3rd AUXILIARY HYDRAULIC SERVICE PORT**  
powers attachments that require multiple hydraulic actuation.

**QUICK CHANGE CONTROL PATTERN SELECTOR VALVE**  
enables operators to quickly choose the operating pattern with which they are most familiar.

**OPTIONAL LONG ARM**  
increases the excavators working range.

**FUEL TRANSFER PUMP**  
provides for easier machine refueling.

**IMMOBILIZER SYSTEM**  
protects the machine from theft by requiring an ID coded key to start the excavator.

**AUXILIARY POWER SOURCE**  
on the top of cabin allows for easy attachment of a rotating beacon light.

**AIR SUSPENSION SEAT**  
provides additional operator comfort through an air support system.



# TB1140